

Perceive<sup>®</sup> Ergo<sup>®</sup> is a best-in-class AI processor providing datacenter-class inference inside power-constrained edge devices.

Sending video and audio from consumer devices to the cloud for storage and interpretation costs too much power, money and time. The process also raises privacy and security concerns. Ergo is a novel inference chip combined with a rich set of development tools to enable even large-scale neural networks to run inside edge devices with groundbreaking power-efficiency.

Perceive Ergo can support a wide range of applications, including face, person, object and audio event detection, face recognition, and others. Ergo is ideal for security cameras, smart doorbells and locks, connected thermostats, home robots, action cameras, drones, AR/VR headsets, and other consumer and enterprise products.

- 1. High performance**  
Large-scale neural networks running at video frame rates
- 2. Ultra-high power efficiency**  
20-100x improvement versus alternatives
- 3. Flexibility**  
Support for a wide range of neural network architectures – not just CNNs
- 4. Capability**  
Support for multiple neural networks running in parallel on a single device
- 5. Security**  
Encrypted models & access to ensure data remains safe

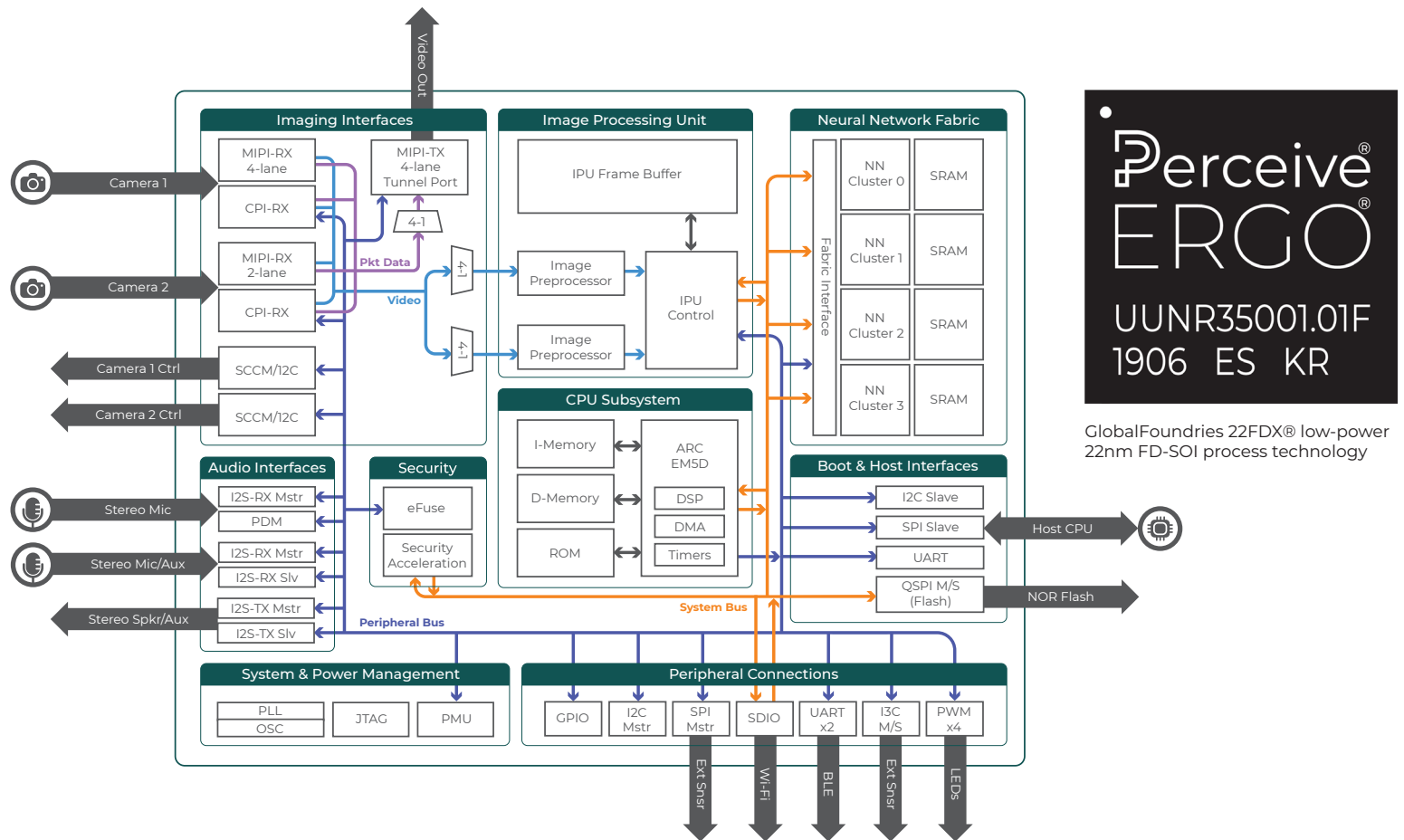

GlobalFoundries 22FDX<sup>®</sup> low-power 22nm FD-SOI process technology

Product Summary				
Name	Operating Voltage	Operating Frequency	Package	Image Sensor Resolution Support
Ergo	Core VCS: 0.8V Core VDD: 0.8V	250 MHz (CPU / IPU / Fabric)	7mm x 7mm FBGA 144 Balls at 0.5mm pitch	2560 x 1440 (2K) @ 60FPS
Ergo Low Power (LP)	Core VCS: 0.8V Core VDD: 0.65V	250 MHz (CPU / IPU / Fabric)		2560 x 1440 (2K) @ 60FPS
Ergo High Performance (HP)	Core VCS: 0.8V Core VDD: 0.8V	310 MHz (CPU / IPU / Fabric)		3840 x 2160 (4K) @ 30FPS

## Features and Specifications

### Security

- Authentication and encryption of embedded software and neural network assets
- Hardware accelerated authentication and decryption for rapid application load times

### Microprocessor

- ARC EM5D RISC/DSP processor
- 32x32 register file
- 256 kByte instruction closely-coupled instruction memory
- 256 kByte data closely-coupled data memory
- Integrated 16-channel OMA
- Integrated interrupt controller
- Integrated 32-bit timers (x2), watchdog timer & real-time counter
- DSP functions
  - Trigonometric & square-root accelerators
  - 32x32 MUL/MAC unit
  - Fractional datatype support
  - Complex/Butterfly operations, vector operations, saturation/rounding operations

### System Features

- Operating frequencies scalable at runtime for best application power/performance fit
  - Programmable fractional spread-spectrum capable System PLL
  - Dedicated programmable fractional MIPI-CSI-Tx PLL
- Integrated low-power crystal oscillator (20-25MHz)
- 1 kbit eFuse array for customizable operating modes and security keys

### Neural Network Fabric

- Supports a wide range of neural network architectures with sizes of over 100 million parameters
- Supports multiple neural networks running concurrently
- Supports multiple input data types concurrently (e.g. video, audio)

### IPU

- Dual, simultaneous image processing pipelines
  - One high-performance pipeline
  - One standard-performance pipeline
- Image Formats : RAW 8/10/12
- Supported Functions:
  - Crop, Clip, Planarize, Down-sample, Decimate, Color conversion, Histogram, Distortion correction, Normalize

### External Memory Support

- QSPI NOR FLASH, 8MB - 256MB for embedded software, neural networks, and persistent storage
- eMMC or SD NAN D memory for applications and data storage
- Optional memoryless boot and application provisioning from a host processor

## Ports and Interfaces

### Sensor & Control Interfaces

- SPI Master
- I3C Master/Slave
- I2C Master
- UART
- GPIO
  - Up to 44 1.8V GPIO pins
  - Up to 8 3.3V/1.8V GPIO pins
- PWM
  - Up to 4 programmable outputs
- 2x SCCM/I2C Master port

### Imaging

- MIPI CSI-2 Rx 1.5Gbps, 4-lane input
  - For image resolutions, see Product Summary table
- MIPI CSI-2 Rx 1.5Gbps 2-lane input
  - 2560 x 1440 (2K) @ 60FPS
- MIPI CSI-2 Tx 1.5Gbps 4-lane output tunnel
- 2x 10-bit Camera Parallel Interface (CPI)
  - 1920 x 1080 (FHD) @ 30FPS
- 2x SCCM/I2C Master Camera Control Ports

### Data & Storage Connections

- SD/eMMC/SDIO
  - SD NAND Flash devices
  - eMMC NAND Flash devices
  - SDIO Wi-Fi devices
- UART
  - Bluetooth Low Energy (BLE) devices

### Host Interfaces

- SPI Slave
- I2C Slave

### Boot Interfaces

- QSPI Master
- QSPI Slave